



Entergy®

**CUSTOMER INSTALLATION
STANDARDS FOR GAS
SERVICE**

INFORMATION AND REQUIREMENTS

for the

INSTALLATION AND LOCATION

of

GAS SERVICES AND METERING EQUIPMENT

**Entergy Louisiana, LLC
Entergy New Orleans, LLC**

JANUARY 2018

FOREWORD

These Gas Service Standards have been prepared for the purpose of providing general information to assist Entergy gas customers and their representatives in the planning for and installing of natural gas service facilities.

The information and suggestions contained in this publication are presented for the guidance of customers and/or their plumbing contractors, licensed gas fitters, architects, consulting engineers, building contractors and other persons involved in planning and installing the customer's gas fuel line. This document is not intended to replace the applicable codes, regulations, statutes, terms and conditions of service or other requirements on file with and approved by the regulator. In cases of conflict between two documents, the documents on file with the regulators will control.

Although this document addresses many situations and circumstances pertaining to gas services in the Entergy Gas System, it is not intended to address every potential gas related matter. If additional information is needed or there is a problem concerning a gas service, Company has representatives that will discuss and/or meet with you upon request.

These Gas Service Standards may be revised from time to time as new methods and improved equipment are developed or utilized. Revisions will be sent to you if Company has your current address on file. Copies of this document are available upon request.

Questions regarding this information should be directed to Entergy's Gas Design group by calling 1-800-Entergy (368-3749).

TABLE OF CONTENTS

	Page No.
FOREWORD.....	2
TABLE OF CONTENTS.....	3
PART 1 - GENERAL.....	5
1. PURPOSE	5
2. DEFINITIONS.....	5
3. INQUIRIES.....	6
4. REQUESTS FOR GAS SERVICE.....	7
5. APPROVALS.....	7
6. APPLICATIONS	7
7. DEPOSITS.....	7
8. CUSTOMER RESPONSIBILITIES	8
PART 2 - GAS DELIVERY PRESSURES.....	9
1. PRESSURE AVAILABILITY	9
2. STANDARD DELIVERY PRESSURES	9
3. SPECIAL CONSIDERATIONS	9
PART 3 - GAS METER INSTALLATIONS	10
1. GENERAL	10
2. SPACE REQUIREMENTS FOR METER SETS	10
3. OBSTACLES AFFECTING METER SET LOCATIONS.....	10
4. EXTERIOR SMALL METER SET LOCATIONS	11
5. EXTERIOR LARGE METER SET LOCATIONS	12
6. INTERIOR METER SET LOCATIONS	13
7. METER TYPES AND SIZES	13
8. METER COSTS.....	14
9. METER TAMPERING.....	14
PART 4 - NEW SERVICE INSTALLATIONS.....	15
1. GENERAL	15
2. SERVICE LOCATIONS	15
3. OBSTACLES/CLEARANCES	16
4. LIMITS OF OWNERSHIP	16
5. SERVICE VALVES	16
6. SERVICE MAINTENANCE	16
7. MAIN EXTENSIONS	17
8. SERVICE AND MAIN PIPING	17
9. CUSTOMER COSTS AND CONTRIBUTIONS	17
10. SERVITUDE AGREEMENTS.....	17

PART 5 - RELOCATION OF EXISTING FACILITIES.....	18
1. GENERAL	18
2. ACCEPTABLE LOCATIONS.....	18
3. CUSTOMER COSTS AND ALLOWANCES	18
PART 6 - GAS LOAD INCREASES.....	19
1. GENERAL	19
2. GAS SERVICE ADEQUACY	19
3. CUSTOMER COSTS AND ALLOWANCES	19
PART 7 - GAS SERVICE TURN OFFS AND TERMINATIONS	20
1. BY CUSTOMER REQUEST.....	20
2. OTHER CAUSES	20
PART 8 - REASONS TO CALL ENTERGY	21
1. DETECTING GAS ODORS	21
2. A COMPREHENSIVE LIST.....	21
PART 9 - ATTACHMENTS - DRAWINGS AND DIAGRAMS.....	22

PART 1 - GENERAL

1. Purpose

The information and suggestions contained in this publication are intended to provide guidance to our customers and/or their plumbing contractors, licensed gas fitters, architects, consulting engineers, building contractors and other persons involved in planning and installing the customer's gas fuel line. This document is not to be used to replace applicable codes, regulations and/or other requirements of regulatory agencies.

This publication is intended to address the majority of the situations and circumstances associated with gas services in the Entergy Gas System; however, it cannot include complete information to every potential gas related matter. If additional information is needed or you feel there is a problem concerning a gas service, Company has representatives who will discuss and/or meet with you upon request.

2. Definitions

Company – Entergy Louisiana, LLC and Entergy New Orleans, LLC both subsidiaries of Entergy Corporation.

Cubic Feet per Hour (cfh) – Basic unit of measure for determining volumetric flow rate of a fluid at a given temperature and pressure.

Customer – A present or prospective user of Company's gas service. The customer may be represented in person or by an architect, consulting engineer, building contractor, licensed gas fitter or plumber or by any other person who has been duly authorized.

Customer Contribution – The portion of the total company cost associated with a service installation or modification project that is the customer's responsibility.

Fuel Line - All piping, generally owned and installed by the customer, extending from the point of delivery to the outlets supplying the customer's gas appliances or equipment.

Large Meter Sets - The meter and all associated equipment used for customers having a gas load of 3,000 cfh or more at a pressure greater than or equal to 1/4 psig.

Load - The amount of gas delivered or required at any point on the gas system measured in cubic feet per hour (cfh) or British thermal units (Btu's) at a requested delivery pressure measured in pounds per square inch gauge (psig).

Equation: 1 cfh = approximately 1,000 Btu's

Main – The gas piping of a distribution system that serves as a common source of supply for more than one service.

2. Definitions (continued)

Meter – The equipment/device used to measure and indicate the volume of gas that has passed through it. The meter is a part of Company's service installation and is owned by Company.

Pressure (usually expressed in pounds per square inch above atmospheric pressure, i.e., gauge pressure – psig) – Pressure applied to a fluid (i.e., natural gas) within a distribution system creates flow. Both pressure and flow are regulated, monitored and measured within the system.

Point of Delivery – The connection point of Company piping and customer fuel line on the outlet side of Company's meter, unless a Service Agreement specifies otherwise or, where such piping will be connected if a connection has not been made.

Service – The piping, generally owned and installed by Company, that carries gas from the main to the meter.

Service Riser – The vertical portion of pipe that extends from the grade of the service piping to the level of the meter header. A part of Company's service installation.

Service Turnoff – The closing of the service valve or riser cock stopping the flow of gas to a customer's fuel line and appliances. This may include the shackling of the service valve and/or the removal of the meter.

Service Termination – The cutting off or severing of an existing service from a gas main. The terminated service can either be abandoned in place or removed.

Small Meter Sets – The meter and all associated equipment used for customers having a gas load of less than 3,000 cfh at a pressure of ¼ psig

3. Inquiries

The telephone numbers you should be aware of for questions, reports or situations concerning a gas service are listed in the table below:

WHO TO CALL		
For	in Baton Rouge	in New Orleans
All inquiries concerning Gas Services	1-800-"ENTERGY" 1-800-368-3749	1-800-"ENTERGY" 1-800-368-3749
City Inspections and Approvals	389-3230	565-6153

CALL 800 272 3020 • WAIT 48 HOURS • RESPECT THE MARKS • DIG WITH CARE

4. Requests for Gas Service

All requests and inquiries concerning a gas service should be made by calling the "Entergy Customer Service System" at 1-800-"ENTERGY" (1-800-368-3749). An operator will record all information pertinent to the request and transmit that information to the proper persons for prompt attention. A reasonable amount of time will be required by Company to make service installations or adjustments. For this reason, arrangements by the customer should be made as soon as possible to better ensure that the service is available when it is needed.

5. Approvals

Local government authorities require that the customer's representative (person, firm or corporation installing the customer's fuel line) secure an approval from the proper department or agency responsible for inspecting the customer's gas facilities. Company cannot perform, under any condition, this particular inspection. All required approvals must be obtained before Company can make service connections to a new fuel line or turn on the gas to an existing fuel line that either has been inactive for an extended period or has undergone additions or alterations. Approvals are to be obtained in the Baton Rouge area from the Chief Plumbing Inspector, City of Baton Rouge/East Baton Rouge Parish and in the New Orleans area from the Chief Mechanical Inspector, Department of Safety and Permits, Mechanical Inspection Bureau, City of New Orleans. See "Inquiries" in Section 3 of this Part for the appropriate telephone numbers. It is the responsibility of the customer to address all fees associated with the City's approval.

6. Applications

Applications, information verifications and any other forms required by Company will be provided to the customer in a timely manner and on an "as needed" basis. The customer will be responsible for securing and completing all other applications required by others.

7. Deposits

Company may require a deposit from the customer before an initial service request can be honored. The deposit will earn interest that will be credited to the customer at scheduled intervals of time. The full amount of the deposit, along with any unpaid interest your deposit has earned, should be returned to you provided your account is cleared of all debt. This return will be made at a pre-determined time or no later than when the account is closed.

8. Customer Responsibilities

The customer is responsible for the following:

- A. Obtaining and paying for (if applicable) approvals of inspection from the proper authority. This must be done before gas service connections can be completed.
- B. Paying any applicable deposits or customer contributions (charges) for service, if applicable, to Company.
- C. Providing an appropriate location on the customer's property for the installation of meters and other equipment if applicable as specified in the Entergy Gas Guidelines.
- D. Proper care for Company's meter and other equipment on the customer's property. The customer will be held responsible for any losses or damages to company property caused by abuse or neglect.
- E. The use of gas service after it passes through the meter.
- F. Checking for gas leaks on and maintaining the gas fuel line and appliances. This does not include meters. If you feel there is a problem with Company's meter, call Company immediately.
- G. Lighting or turning off gas pilots. Upon request, Company will assist the customer with these functions but cannot guarantee a specific time of performance.
- H. Immediately informing Entergy if you believe there is a problem with your gas service or gas bill.

PART 2 - GAS DELIVERY PRESSURES

1. Pressure Availability

Company's gas network consists of numerous pipeline systems of various pressures. A customer's particular gas service will be supplied from connections to the gas system with those points of connection being determined by Company. That decision will be based on the type and magnitude of the gas load requested by the customer along with the location of the requested service. The fact that a certain type of gas service is supplied in a given area does not mean that every customer can be supplied with the same type of service. It may be necessary that an extension be made of the distribution system supplying the type of gas service required. See Part 4 of Section 7 for details on main extensions.

2. Standard Delivery Pressures

Company will provide natural gas to all residential gas customers at approximately 1/4 psig delivery pressure (approximately 6 to 7 inches water column). Company can provide natural gas to all commercial and industrial customers at of either 1/4 psig, 5 psig or 10 psig depending on load requirements and pressure availability.

The following table is a quick reference of the standard delivery pressures available for the different type of customers in the Entergy Gas System:

Type of Customer:	Standard Delivery Pressure
Residential	1/4 psig (6-7 inches-water column)
Commercial	1/4 psig, 5 psig or 10 psig
Industrial	1/4 psig, 5 psig or 10 psig

If a pressure, lower than any of the abovementioned standard delivery pressures, becomes necessary, it is the customer's responsibility to reduce the pressure on their fuel line or at the appliance.

3. Special Considerations

On very rare occasions, it becomes necessary for a commercial or an industrial customer to request natural gas at a delivery pressure greater than Company's highest standard of 10 psig. Company will consider providing the requested delivery pressure, up to the line pressure of the system, only when all other options to satisfy the situation have been exhausted and if the system can accommodate it. Where the use of flexible tubing fuel lines is acceptable to the local governing bodies, Company can provide up to two (2) psig for residential customers.

PART 3 - GAS METER INSTALLATIONS

1. General

A meter will be identified by a meter number that is issued and recorded by Company. There will be only one meter installed per customer at any given address. Whenever more than one meter is needed to supply a number of customers in the same building, such as for doubles or apartments, the total lot of meters pertaining to that building shall be grouped at one point and fed from one service. This will ensure that they are accessible for reading, maintenance and service for both company and emergency personnel.

All meters and associated metering equipment will be furnished, installed and maintained by Company. If the customer believes that the meter is not functioning properly, it should be brought to the attention of Company as soon as possible. Company will investigate the situation and make the necessary adjustments. Company is not responsible for service interruptions caused by factors beyond its control. Under no circumstances should the customer try to adjust or work on the meter set.

2. Space Requirements for Meter Sets

In order for Company to honor the request for a new or relocated meter set, the customer must provide a location on the customer's property that is readily accessible, protected and satisfactory to Company. The space requirements should be determined prior to the installation or relocation of the customer's fuel line in order to avoid unnecessary delays or expenses. Large meter sets placed in buildings or fenced enclosures have specific space requirements and are described in detail in Sections 5 and 6 of this Part. The meter set must remain accessible at all times. If the meter set becomes inaccessible, Company may have to relocate it to a more suitable site on the customer's property at the expense of the customer. A customer requested meter location, different from the one determined by Company, can be utilized provided it meets the appropriate requirements. There may be some incremental customer costs associated with such a location.

3. Obstacles Affecting Meter Set Locations

When determining an acceptable location for a meter set, there are numerous objects that should be avoided or sufficiently cleared. Also, after the meter has been set, the placement or construction of any of these objects near the existing meter could cause the meter set location to become unacceptable. If Company finds it necessary to relocate the meter due to a conflict created by the placement of any object or type of object listed below, it will be done at the expense of the customer. If the customer intends to install any object near an existing meter set, they should contact Company prior to any work being done. A company representative will discuss different acceptable options that can be taken as to eliminate potential conflicts and expenses.

The following table identifies some of the items or object types that can affect a meter set location.

3. Obstacles Affecting Meter Set Locations (continued)

ITEMS AFFECTING METER SET LOCATIONS	
All sources of ignition	Walkways
All gas fired equipment	Doors
Air conditioners	Faucets
Windows	Electric meter facilities
Exhaust vents (e.g., dryers)	Ventilation intakes
Downspouts	Driveways

See Sections 4 through 6 of this Part and Drawing GSS:9-1 of Part 9 for a more detailed look at these items and how they should be avoided.

4. Exterior Small Meter Set Locations

Small meter sets generally are used in residential and small commercial applications. The following items, in conjunction with drawings GSS:9-1 and GSS:9-2 of Part 9, should be noted when determining standard exterior small meter set locations.

- A. The end of the customer's fuel line that connects to the meter shall be located approximately 5 feet from the front end of the house. The fuel line should terminate 24 inches above the finished grade and where emerging from the wall, project 2 inches from the wall and end with a male thread.
- B. The closest edge of a meter set should be at least 18 inches from a water faucet or a splash type downspout.
- C. The meter set shall be at least 3 feet from any possible source of ignition, such as air conditioners, gas fired equipment, etc.
- D. The meter set shall not be placed within a 3 feet radius of any building openings such as windows, doorways and dryer vents to ensure that any escaping gas goes freely into the atmosphere.
- E. No electrical equipment should be installed in an area between two imaginary lines placed vertically at 12 inches from each side of the meter when above the meter set or within a 3 feet radius of the nearest edge of the meter when below the top of the meter set. See shaded area, Drawing GSS:9-1, Part 9.
- F. The meter set shall not be placed in a walkway. There must be a minimum distance of 1 foot from the edge of the building that the meter set serves to the nearest edge of the walkway. See Item "H" below.

4. Exterior Small Meter Set Locations (continued)

- G. All efforts should be made to install the meter on the building side opposite the driveway. If this is not possible and there is no alternative but to place the meter set next to a driveway, the customer must provide either of the following:
- 1) A 3-foot minimum clearance between the side of the building and the nearest edge of the paved driveway
 - 2) A company approved pipe barricade to insure protection for the meter set or
 - 3) Space to raise the meter set as described in Item "H" below.
- H. In areas prone to flooding or if the meter set is obstructing a walkway and/or driveway bordering the building being served, the meter set can be installed high on the side of the building with a minimum clearance of 6 feet and 6 inches between the bottom of the meter set and the established grade. This can also be used as an alternative solution to the situations described in items "F" and "G" of this Section.
- I. Every effort should be made to avoid placing the meter installation under pier foundation houses. Where unavoidable, there shall be a minimum clearance of 26 inches from the under side of the floor joists to the established grade. The preferred location of the meter set assembly is the first opening from the front of the house and as close to the face of the opening as possible while still receiving protection from the house.

5. Exterior Large Meter Set Locations

Large meter sets are generally used for large commercial or industrial customers. The following items, in conjunction with drawing GSS:9-3 located in Part 9, should be noted when determining standard exterior large meter set locations.

- A. A designated area on the customer's property shall be provided by the customer. It should be readily accessible and used solely for a gas meter set.
- B. Company should be consulted prior to any work being done on the customer's fuel line in order to determine an acceptable size and location of the area to be provided.
- C. Security and/or additions such as pipe barricades, slabs and fences are to be installed if determined necessary by Company. Installation of these items shall not interfere with the operation of the meter set and are to be provided by and at the expense of the customer.

6. Interior Meter Set Locations

Under certain circumstances, when all options for an exterior location have been exhausted, the meter set will be allowed to be located inside the building being served. There are different requirements for small and large meter sets. The following items describe in detail the necessary requirements.

- A. For small meter set installations, the room in which the meter is located must be ventilated and at least three (3) feet from any sources of ignition or heat.
- B. For large meter set installations, the following requirements should be met.
 - 1) A designated room, inside the building that is to be served and readily accessible, shall be provided by the customer.
 - 2) Company should be consulted prior to any work being done on the customer's fuel line in order to determine an acceptable size and location of the designated meter room.
 - 3) The designated meter room is to be used exclusively for gas metering and regulating. No storage of any kind can take place inside this room.
 - 4) A 5-foot minimum double metal door, including an approved dead bolt lock with tumblers mastered to a key provided by Company, is required.
 - 5) The double doors, as described in Item "4" above, shall be louvered if they open to outside atmosphere. If they do not open to outside atmosphere, at least 2 louvers each having an area of 12 inches x 12 inches (or equivalent) shall be installed in the outside wall(s) of the meter room.
 - 6) If lighting is necessary, all electric fixtures and wiring shall be explosion proof and meet all applicable building code requirements.
 - 7) There shall be no opening of any kind in the room, except for the required doors and/or louvers, unless a written exception is made by the appropriate Gas Network Manager.

7. Meter Types and Sizes

The type and size of meter required at any location shall be determined by Company and will depend on the size and nature of the customer's gas load. The meter set is the responsibility and property of Company. At no time should the customer try to adjust or alter the meter in any way.

8. Meter Costs

Generally, there are no charges to the customer for the installation of a meter set. In the event the customer is determined responsible for a portion of the meter installation costs, they will be included with the gas service costs. These charges are based on the determined location of the meter to be installed, the gas load criteria, and the costs associated with additional facilities necessary to ensure the protection of the meter set installed. All meter charges, other than for new installations, are considered relocations and are described in detail in Part 5 of this document.

9. Meter Tampering

Meter tampering can lead to serious physical injury and/or property damage. Only Company-authorized employees are allowed to handle meters and break or remove the meter seals. Company employees are prohibited from allowing or helping anyone else do so for any reason.

Company has an active program to detect evidence of meter tampering. If meter tampering is detected, the suspects will be subject to criminal prosecution. In addition, if Company removes a meter from a customer's property due to tampering, service is suspended until all bills and charges have been paid, including charges of the estimated usage for the periods in which meter tampering occurred.

PART 4 - NEW SERVICE INSTALLATIONS

1. General

The following list has been generated in an effort to provide customers with the basic facts concerning a gas service installation in the Entergy Gas System. It should be referred to when planning to make a request for a new gas service.

- A. All services, even when on the customer's property, shall be installed, owned and maintained by Company.
- B. The service location should be identified by the municipal number and street where the service is to be installed.
- C. There will be only one service to each building or group of buildings having a common address.
- D. The length of the service should be kept to a minimum. Company generally will provide service to ensure that a meter is placed in a pre-determined location bordering the building being served. It should be noted however that there will be, on occasion, certain circumstances preventing Company from doing this. On those occasions, Company will provide service to a point on the customer's property acceptable to Company.
- E. It may be necessary to secure a gas servitude agreement in order to honor some service requests. See Section 10 of this Part for details.
- F. The final connection to a gas service must be made by an authorized employee of Company. It can be made only after all approvals have been obtained from the proper authorities as required by the local governing bodies. For details on "Approvals," see Section 5 of Part 1.
- G. Call the telephone center as described in Section 3 of Part 1 to make a request for gas service as soon as possible, so the job can be scheduled and delays avoided.

2. Service Locations

The gas service location will be determined by Company. It will generally be installed at the shortest distance from the point of connection with Company's gas main (tap) to the location of Company's metering equipment for the property to be served. It may be necessary to deviate from that location when certain obstructions and/or obstacles are present. A listing of those obstructions and/or obstacles in Section 3 of this Part should be noted.

When a gas service is installed on property of the customer, it will be done so with at least 12 inches of cover.

No other facilities shall be installed in the gas service trench unless done so by company forces.

2. Service Locations (continued)

In the event the customer plans to excavate or dig for any reason around a gas service, Louisiana One Call and/or Company should be contacted at least 2 working days prior to the work being done in order to obtain an exact location of the service in question.

3. Obstacles/Clearances

The location and length of a service may deviate from that of the shortest distance as described in Section 2 of this Part due to conflicts with obstructions and providing for the necessary clearances of those obstructions. Some, or all, of the additional costs associated with providing clearances to obstructions may be added to the customer contribution. The following table identifies some of those obstacles:

ITEMS AFFECTING SERVICE LOCATIONS	
Some types and sizes of trees	Swimming pools / fountains
Underground utilities	Vaults
Manholes	Poles
Walkways	Driveways
Walls	Brick, stone or other pavings
Small structures	Slabs

4. Limits of Ownership

The ownership of a gas service transfers from Company to the customer at the point of delivery. All piping and appliances located on the customer's side of the point of delivery shall be furnished, installed and maintained by and at the expense of the customer. All piping and devices located on Company's side of the point of delivery shall be owned, furnished, installed and maintained by Company. Company will be responsible for making the final connection.

5. Service Valves

Each gas service will have a shut off valve in a readily accessible location that, if feasible, is outside the building. When not feasible and the service is for a place of public assembly, a sidewalk valve shall be installed

6. Service Maintenance

All maintenance to a gas service, even if on the customer's property, shall be performed by Company. If the customer feels there is a problem with the gas service, Company's Customer Service Center should be called immediately as specified in Section 3 of Part 1. The customer is responsible for all maintenance on the fuel line and gas appliances. If there is a question as to the source of the problem, Company should be called to identify the source.

7. Main Extensions

In certain locations within Company's service area, the system's distribution facilities will not be adjacent to a property where a request for gas service, or one of a specified pressure is being made. When this situation occurs, a gas main extension becomes necessary to accommodate the request. All main extensions will be designed, constructed, operated, maintained and removed by Company. Company generally installs its gas distribution mains in public right-of-way or in street and/or sidewalk locations. There are some instances where it may be beneficial or mandatory for the main to be installed on private property. In this case, it will be necessary to secure a gas servitude agreement. See Section 10 of this Part for servitude agreement details.

8. Service and Main Piping

The size and type of service and, if necessary, main piping required at any location shall be determined by Company. They will be determined based on the size and nature of the customer's requested gas load with respect to that portion of the gas system the addition will affect.

9. Customer Costs and Contributions

The customer's cost for a new service, or customer contribution, will vary depending on the location of the service being requested and what the request entails. It will be calculated by company personnel and in accordance with the most recent gas service regulations that are on file with the authorities having jurisdiction over the service area from which the request is being made.

10. Servitude Agreements

There will be occasions when it is either required or beneficial to install a gas service and/or a main extension on private property that is not owned by the customer requesting the service. The majority of gas servitude agreements will be secured due to one of the following reasons:

- A. Public right of way is not accessible or available.
- B. The owner or developer of a private property that is to be subdivided requests gas facilities for that subdivision.
- C. There is a parcel of land that would be beneficial to cross but is the private property to a party other than the one requesting the gas service.

The servitude agreement is a written legal document between Company and the owner(s) of the property in question. It grants Company the right to construct, operate, maintain and remove necessary gas facilities over and across the private property. The obligation of Company to furnish the requested gas service is contingent upon its ability to finalize and secure a recordable servitude agreement from all necessary parties and at no cost to Company.

PART 5 - RELOCATION OF EXISTING FACILITIES

1. General

When changes or additions to an existing customer's property are anticipated, the meter and service riser may be found to be in conflict with those proposed changes. Whenever, in Company's judgment, the space provided for its meter set and/or other gas equipment becomes inaccessible or otherwise unsuitable, Company will have to relocate its facilities to a new location on the customer's property.

All requests for relocations should be made by placing a telephone call to the Customer Service Center as described in Section 3 of Part 1. Company should be notified as soon as possible to eliminate, or at least keep to a minimum, any delay that a relocation may cause and also to coordinate the connection of the fuel line with Company's new meter/riser location. The customer is responsible for rearranging their fuel line so it can be connected to Company's relocated installation.

No work can take place until all applicable approvals from the local government authorities have been secured as mentioned in Section 5 of Part 1. At no time should anyone other than a company employee relocate the meter set or any other portion of Company's service.

2. Acceptable Locations

When a relocation is requested, the meter set and/or other gas facilities are to be moved to a new location on the customer's property. As is the case with new services, there are items around a building that should be avoided or sufficiently cleared when determining an acceptable site for the relocation. Those items and their associated clearances are described in detail in Sections 2 through 7 of Part 3. The new location should be determined or at least accepted by Company.

3. Customer Costs and Allowances

Whenever, in Company's judgment, it is necessary to relocate the meter set and/or other gas facilities due to changes or additions made to the customer's property the entire cost of that relocation, including fuel line adjustment costs, shall be borne by the customer. If the requested relocation benefits Company in any way, the customer contribution will be adjusted lower from that of the total cost of relocation.

Company will relocate, at no charge to the customer, the meter set from the inside of a building or basement to an acceptable location outside the building. If the customer wants to extend the location beyond that of Company's suggested location, the entire cost of that extended portion, along with costs to adjust the customer's fuel line, shall be borne by the customer.

PART 6 - GAS LOAD INCREASES

1. General

When a customer makes additions to the number of gas appliances, or increases the size of the existing gas appliances, the total gas load for that service will increase accordingly. This action may require Company to adjust the existing gas facilities used to serve that customer.

As is the case with any situation that could have an effect on a customer's gas service, Company should be notified of any anticipated load increase as soon as possible. At this time, a gas service adequacy check should also be requested. Refer to Section 3 of Part 1 for the telephone number of the Customer Service Center to make that request.

2. Gas Service Adequacy

The customer's existing gas facilities, in most cases, are able to accommodate the anticipated load increase. There will be some increases, however, that cause the existing facilities to become undersized. This may require Company to revise the service piping, meter set, or both.

All requests for gas service adequacy checks should be made by the customer. The request must include the load criteria in order for Company to provide an accurate check for adequacy. The customer is responsible for rearranging the fuel line to facilitate the increases.

3. Customer Costs and Allowances

There are no charges passed on to the customer for load increases. In most cases, the existing facilities will accommodate the anticipated load increase. If revisions are necessary to increase the capacity of the existing gas facilities, Company will provide them at no cost to the customer.

PART 7 - GAS SERVICE TURN OFFS AND TERMINATIONS

1. By Customer Request

A customer can request to have their service turned off by placing a telephone call to the Customer Service Center as described in Section 3 of Part 1. Company requires notification of the desired termination at least one (1) full working day prior to the time the termination is needed by the customer. The customer is responsible for all gas consumption up until the time the service is terminated.

2. Other Causes

Other circumstances or actions could cause Company to turn off or terminate a service. Usually it will be for actions, or lack of action, taken by the customer. In an effort to eliminate unwanted turnoffs, a comprehensive list of reasons that Company will turn off or terminate a service has been created and is as follows.

- A. Upon customer request as described Section 1 of this Part.
- B. A customer's non-payment of bills. Before a service is turned off for this reason, Company will send a Disconnect Notice to the customer explaining the procedures the customer must take to avoid this action.
- C. Company receives, from the city, orders to terminate a service due to a customer's property not meeting plumbing codes or having conditions that might cause danger to a person's health or life, or damage to a person's property.
- D. A customer fails to pay the required deposit.
- E. A customer has issued a check for uncollected, insufficient funds.
- F. A customer receives a service by supplying false information or fails to sign a document requiring a signature by a requested date.
- G. A customer or someone other than those authorized by Company, tampers with or otherwise alters or modifies a meter set or any other company facility.
- H. A customer takes action that creates a hazard or possible damage to company facilities.
- I. A customer refuses to arrange for or allow a company employee to read a meter or to inspect, maintain or replace gas facilities.

PART 8 - REASONS TO CALL ENTERGY

1. Detecting Gas Odors

If a customer feels that there is a problem with a service or if the smell of gas is present, they should **leave the area of concern immediately and call the Customer Service Center**. Refer to Section 3 of Part 1 for the proper telephone number.

2. A Comprehensive List

There are numerous reasons that a customer should contact Company. The majority of the calls will be made due to one of the following reasons. If the customer:

- A. Needs a new gas service
- B. Wants an existing gas service relocated
- C. Is going to increase the gas load on an existing service
- D. Wants to cut off or terminate a service
- E. Feels there is a problem with their or with any other person's gas service
- F. Knows of a damaged gas facility
- G. Knows of any service that has been tampered with
- H. Smells gas, even if it is away from a house or building

If you need to call Company for any of the abovementioned situations, or for any other reason, you should contact the Customer Service Center as mentioned in Section 3 of Part 1.

PART 9 - ATTACHMENTS - DRAWINGS AND DIAGRAMS

All drawings and diagrams will begin on the next page.

REFERENCE DRAWING ONLY, NOT FOR CONSTRUCTION

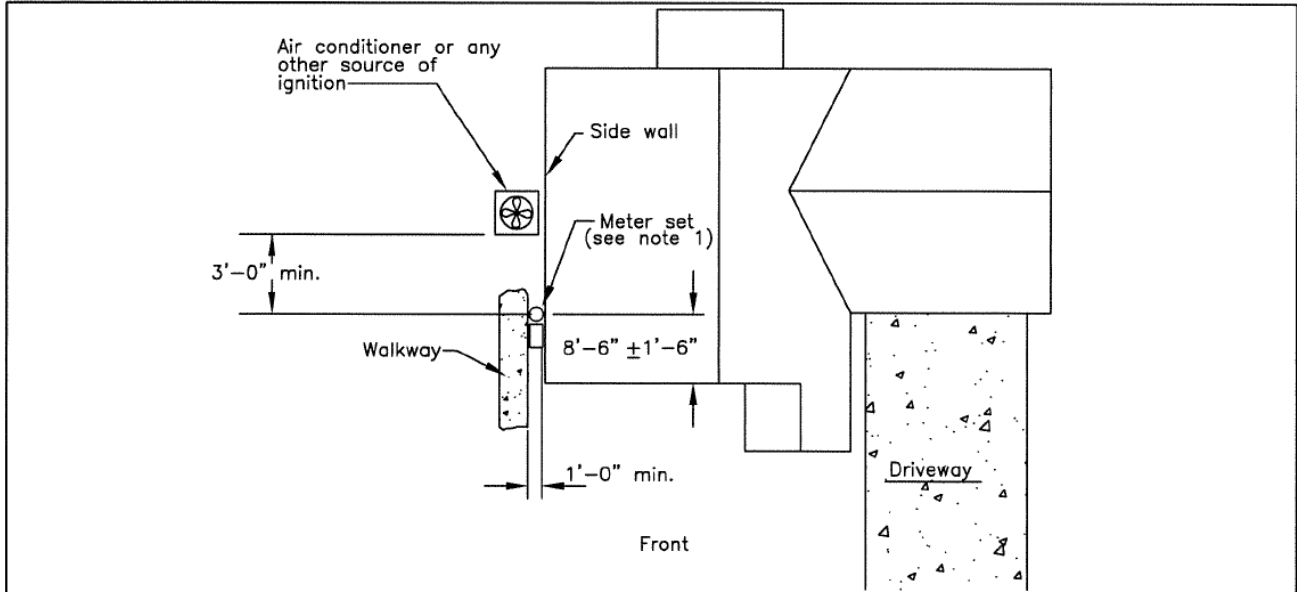

TOP VIEW

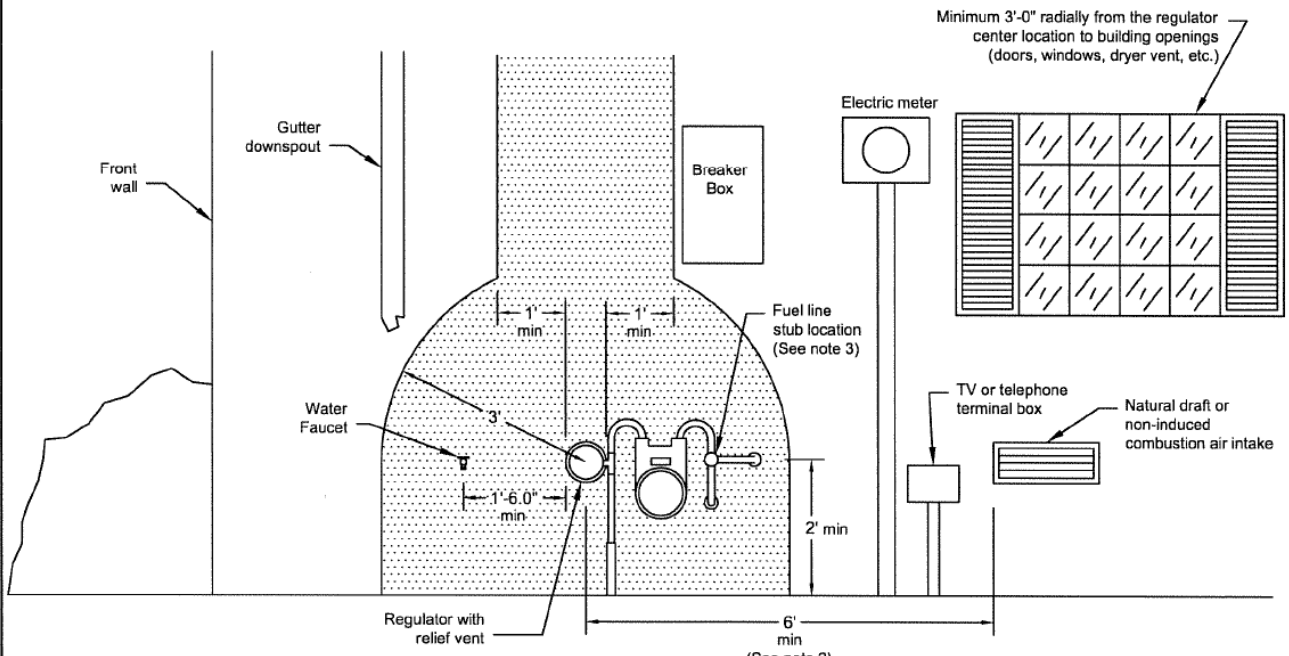

SIDE VIEW

Notes:

1. Meter set should be installed on side of building opposite the driveway.
2. The minimum clearance for a mechanically induced combustion air intake is 6'.
3. The fuel line should terminate 2'-0" above finished grade (mud line), and project 2 inches from the finished wall. See drawing GSS:9-2 of this section for meter set details.
4. If any of the above mentioned clearances cannot be met the details should be coordinated with a representative of the company.

ENTERGY SERVICES, INC.	
RESIDENTIAL/SMALL COMMERCIAL METER LOCATION DETAILS	
APPROVED BY: KDS	DATE: April 1998
CHECKED BY: KDS	SCALE: NONE
DRAWN BY: WINK-AJC	
	No. GSS:9-1
	PLOT 1=1 SH. 1 OF 1

NO.	DATE: 6/24/2015	REVISION 2	BY: RHS	APPR: XXX
-----	-----------------	------------	---------	-----------

REFERENCE DRAWING ONLY, NOT FOR CONSTRUCTION

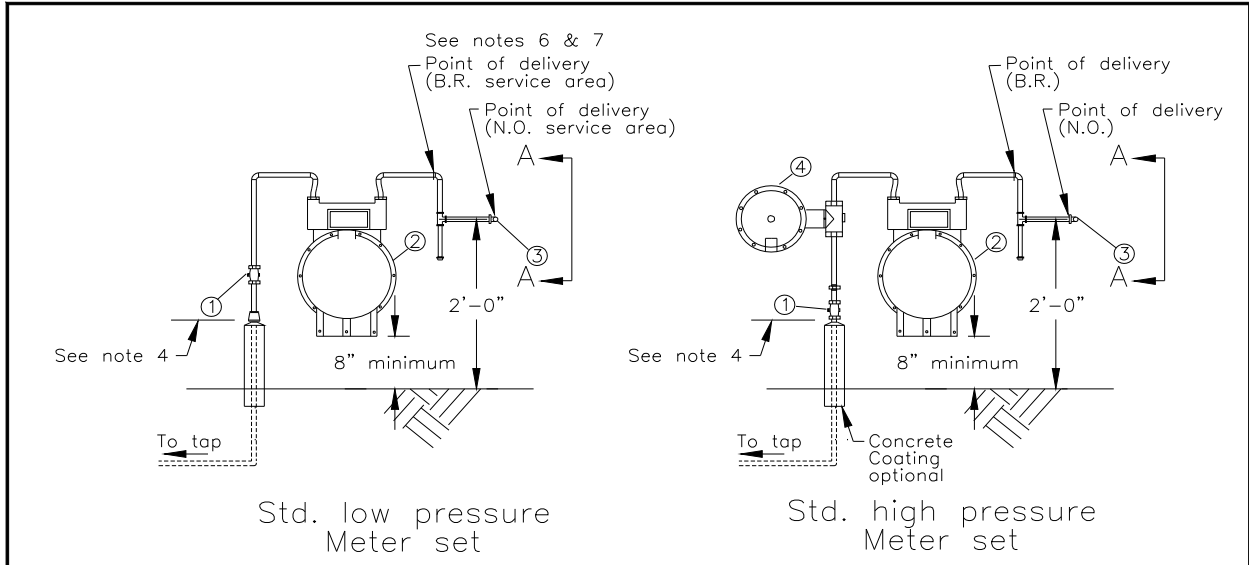

Front view

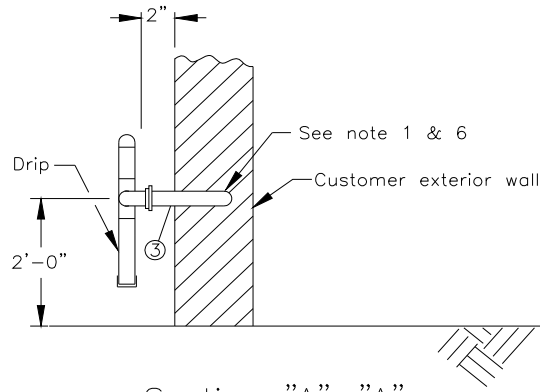

Section "A"-"A"

Notes:

- 1) Customer fuel line to be installed by the customer to the dimensions shown. See drawing GSS:9-1 of this section for meter set locations.
- 2) All meters and associated meter set equipment to be furnished, installed and maintained by the company
- 3) Under no circumstances should anyone other than an authorized Entergy employee work on or attempt to adjust a meter set.
- 4) No ground wires (telephone, cable, elec, etc.) to be attached below this point.
- 5) See part 3, section 4 for documentation.
- 6) In the B.R. service area, the plumber is responsible for the installation of the drip. The point of delivery is therefore located at the inlet to the elbow connecting the drip.
- 7) In the N.O. service area, the plumber is responsible for installing the fuel line stub, extending two inches from finished wall and end with a male thread.

Material

- ① - Riser cock (locking valve)
- ② - Meter (AL-250 in this case)
- ③ - Customer fuel line
- ④ - Regulator

ENTERGY SERVICES, INC.			
TYPICAL SMALL METER SET DETAILS (RESIDENTIAL OR SMALL COMMERCIAL)			
APPROVED BY: KDS	DATE: April 1998		
CHECKED BY: KDS	SCALE: NONE		
DRAWN BY: WINK-AJC			
		No. GSS:9-2	
		PLOT 1=1	SH. 1 OF 1

NO.	DATE:	REVISION	BY:	APPR:
-----	-------	----------	-----	-------

REFERENCE DRAWING ONLY, NOT FOR CONSTRUCTION

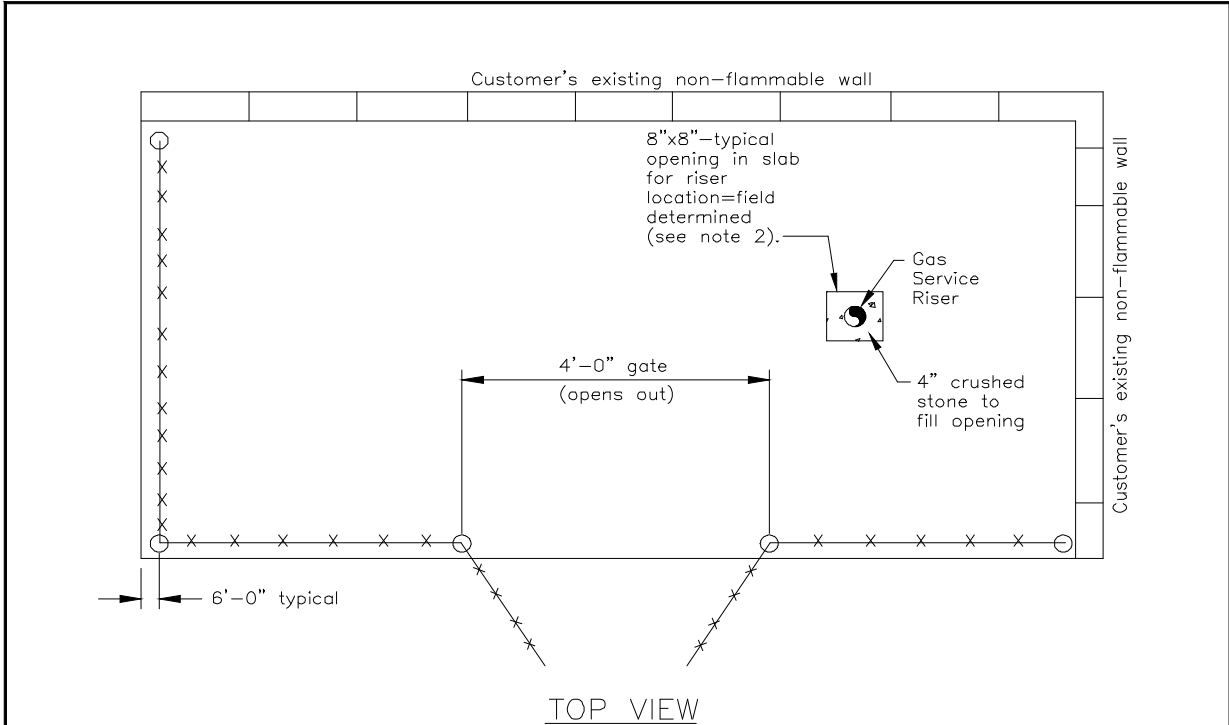

TOP VIEW

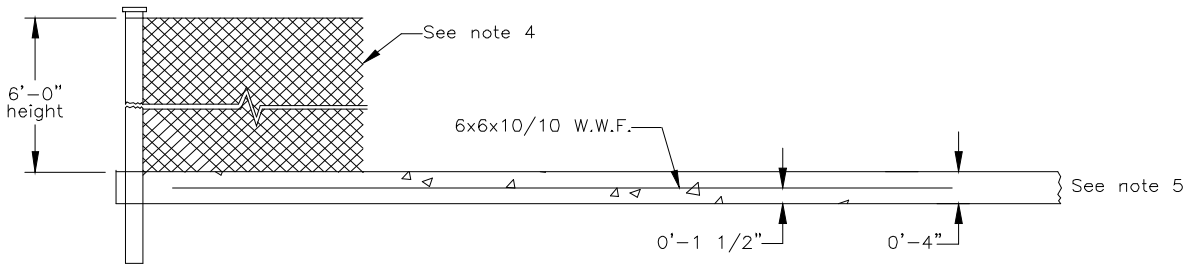

FRONT VIEW

NOTES:

1. Overall dimensions and riser locations to be determined by the company prior to construction.
2. Riser(s) to be installed before slab is poured.
3. Gate typically to be placed at C/L of long side of fence enclosure and situated to open out.
4. 6' high chain link fence to be installed when a customer's existing wall is not available.
5. Slab to be 4" thick, 3000 psi concrete & reinforced with 6x6x10/10 W.W.F.
6. All slab and fence material & installation to be paid by customer.
7. If any of the above notes cannot be adhered to, a suitable arrangement shall be coordinated with a representative of the company.

ENTERGY SERVICES, INC.	
SLAB AND FENCE DETAILS LARGE METER SETS	
APPROVED BY: KDS	DATE: April 1998
CHECKED BY: KDS	SCALE: NONE
DRAWN BY: WINK-AJC	
No. GSS:9-3	
PLOT 1=1	SH. 1 OF 1

NO.	DATE:	REVISION	BY:	APPR:
-----	-------	----------	-----	-------